

# T2E DAILY INSPECTION FORM



TRUCK # \_\_\_\_\_ DRIVER NAME \_\_\_\_\_ DATE \_\_\_\_\_

PERFORM THE FOLLOWING			
	COMPLETE		COMPLETE
CHECK BATTERY CHARGE LEVEL		CHECK COOLANT LEVEL	
CHECK HV (ORANGE) CABLES		DRAIN WATER FROM AIR TANKS	
		CHECK HYDRAULIC TANK OIL LEVEL	
		INSPECT CONDITION OF BATTERY BOXES	

CHECK THE FOLLOWING ITEMS AND INDICATE IF "OK" OR "REPAIR NEEDED". CIRCLE LOCATON ON DRAWINGS IF NECESSARY. DESCRIBE PROBLEMS IN REMARKS AREA AT BOTTOM OF PAGE.

	OK	REPAIR NEEDED		OK	REPAIR NEEDED		OK	REPAIR NEEDED
STEPS / HANDLES / PLATFORMS			STEERING			BACKUP LIGHTS		
STARTER			THROTTLE			BRAKE LIGHTS		
NEUTRAL START			BOOM OPERATION			FLOOD LIGHT (S)		
BACKUP ALARM			5 <sup>TH</sup> WHEEL RELEASE			STROBE LIGHT		
HEATER / DEFROSTER / AC			SERVICE BRAKES			MARKER LIGHTS <i>(IF APPLICABLE)</i>		
MIRRORS			PARK BRAKE			CAB SUSPENSION / LATCH		
DOORS			HORN(S)			FLUID LEAKS		
WINDOWS			TRAILER AIR LINES			MUD FLAPS / FENDERS		
WIPERS			TRAILER LIGHT CORD			TIRES		
SEAT			HEAD LIGHTS			DAMAGE		
SEAT BELT			SIGNAL LIGHTS					

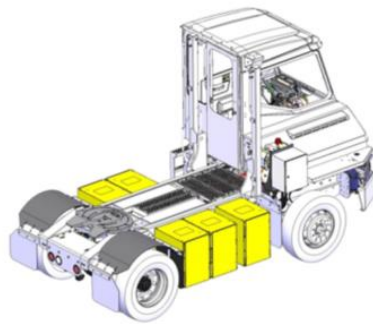

REMARKS:

---



---



---



---



---



---



---



---



---



---